

EXPEDITE

Datasheet

Telemetry, telecommand, tracking, and automation for small-satellite operations.

**4U SDR Appliance****VHF / UHF / S-band****REST + WebSocket + ZeroMQ**

Product	Expedite
Product Class	Ground station SDR transceiver appliance
Applicable Software Baseline	v3.3.2
Form Factor	4U
Coverage Stated in Manual	Amateur VHF, UHF, and S-band
Document Basis	RSS-EXP-MAN-001 Revision 7

Expedite is a 4U software-defined radio appliance for small-satellite TT&C operations. The platform integrates telemetry and telecommand processing, pass scheduling, satellite tracking, Doppler pre-compensation, antenna-control support, diagnostics, and ground-station automation interfaces. The documented baseline supports amateur VHF, UHF, and S-band mission workflows together with TCP/IP, WebSocket, REST, ZeroMQ, and browser-based control interfaces.

Key Features

- Integrated telemetry receive and telecommand transmit processing
- Internal and external Doppler pre-compensation
- Ephemeris processing, satellite tracking, and pass scheduling
- Internal or external antenna-angle generation
- Half-duplex sequencer control for RF path switching
- Monitoring, mission logging, TTC visualization, and spectrum-analysis tools
- TCP/IP, WebSocket, REST, and ZeroMQ integration paths
- Compatibility with selected satellite transceiver families
- Support for hardware radios, VRT streams, and file-based IQ playback

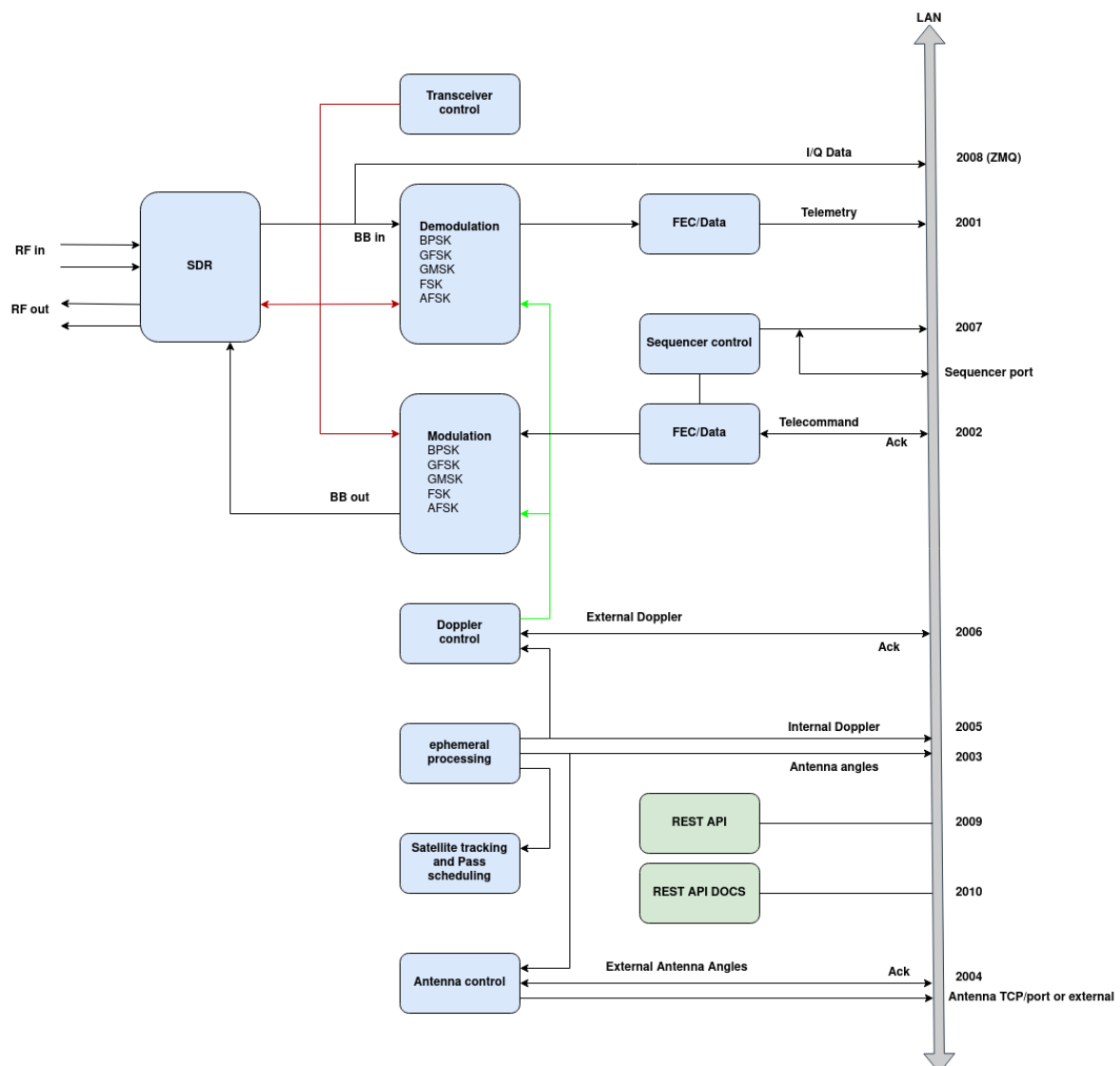

Representative functional architecture.

Core Specifications

Category	Specification
System role	Ground station SDR transceiver appliance for telemetry, telecommand, tracking, scheduling, and ground-system integration.
Frequency coverage stated in manual	Amateur VHF, UHF, and S-band.
GUI tuning ranges	Receive and transmit tuning ranges exposed in the GUI: 70 MHz to 2.5 GHz. Satellite frequency reference field: 70 MHz to 46 GHz.
TM and TC data rate	10 Baud to 25 MBaud
Supported modulations	BPSK, QPSK, FSK, GMSK, AFSK, ASK, GFSK, PCM/PM, and PCM/PSK/PM.
Line codes	NRZ-L, NRZ-M, NRZ-S, BP/Manchester-L, BP/Manchester-M, BP/Manchester-S.
Scramblers	G3RUH and CCSDS additive/randomizer options.
Packet and framing formats	AX.25, HDLC, CADU, AirMac, RAW, and four ASM framing variants.
Data formats	CSP and user-defined formats.
Forward error correction	RS(255, 223), RS(255, 239), CCSDS convolutional CC(7, 1/2), concatenated modes, BCH, and short CCSDS LDPC options as described in the manual.
Telecommand procedures	Open-loop PLOP-1 and PLOP-2. GUI-exposed CMM1, CMM2, and CMM4 timing parameters from 1 to 9999 ms.
Receive and transmit path selection	RX1, RX2, TX1, and TX2.
Gain and tuning controls	Gain 1 to 30; manual frequency offset -1,000,000 to +1,000,000 Hz; loop bandwidth parameters 0.001 to 50; modulation index 0.2 to 1.5.
Pulse shaping	SRRC and Integral with roll-off / BTs value 0.0 to 1.0.
Supported inputs	Supported radios, VRT streams, and IQ files.
Reference inputs	10 MHz and 1PPS.

Tracking, Automation, and Logging

Function	Summary
Ephemeris processing	Internet-fed ephemeris updates, including sources such as Celestrak, with SGP4/SDP4 propagation.
Pass planning horizon	Up to 168 hours.
Antenna control	Internal antenna-angle generation or external antenna-angle input; physical control through TCP/IP or serial.
Doppler control	Internal Doppler generation and external Doppler input are both supported.
Rotor support listed in manual	SPID Rot2Prog, Yaesu, Prosiste1, M2, RotCtrl, and others upon request.
Sequencer control	RF relay switching support for half-duplex operations; control packets are published for use by third-party logic.
Mission logs	Telemetry, Doppler, Tracking, Antenna, Telemetry IQ, and Command IQ; stored under the MissionData directory in the home folder.
Operator tools	TTC Visualizer, Spectrum Analyzer, mission statistics, TTC status, network status, radio control, and pass-oriented operational views.

Diagnostics and Mission Visibility

Capability	Summary
Loopback and link checks	Loopback-oriented validation workflows are documented in the product material.
Link-quality visibility	BER / FER-oriented monitoring context together with telemetry statistics and failure counters.
Spectrum diagnostics	Spectrum analyzer with spectrum, constellation, and distribution views.
Hex-level visibility	TTC Visualizer provides frame and telecommand visibility in hexadecimal format together with metadata.
Mission-history capture	Mission logs, TTC statistics, Doppler status, antenna status, and recorded IQ data support post-pass analysis and diagnostics.

Interfaces and Service Ports

TCP	WS	ZMQ	Service	Notes
2001	3001	4001	Telemetry	Expedite-originated telemetry service.
2002	3002	4002	Telecommand	User-originated uplink path; acknowledgement defined separately by the manual.
2003	3003	4003	Ephemeris antenna position	ZeroMQ path marked as non-MINI_EXPEDITE in the manual.
2004	3004	N/A	External antenna control	User-supplied antenna angles and acknowledgements.
2005	3005	4005	Ephemeris Doppler	Internally generated Doppler.
2006	3006	N/A	External Doppler	User-supplied Doppler input and acknowledgement.
2007	3007	4007	Sequencer control	Half-duplex control publication from Expedite.
N/A	N/A	4008	Raw IQ	High-rate IQ stream over ZeroMQ.
2011	3011	4011	Real-time antenna position	Additional angle/status publication path.
N/A	N/A	4015	Spectrum data	Streaming analyzer output.
N/A	N/A	4016	Constellation data	Streaming constellation output.
N/A	5002	N/A	WebSocket-side API	Real-time API-driven integration.
2009	N/A	N/A	REST API	Full control and status interface.
2010	N/A	N/A	REST API docs	Auto-discoverable documentation endpoint.
3000	N/A	N/A	Web App	Browser-based remote operation interface.

Hardware and Environmental

Parameter	Specification
Form factor	4U.
Dimensions	177 x 482 x 555 mm (h/w/d).
Weight	16 kg.
RF connector	SMA female.
Operating temperature	+10°C to +40°C.
Front hardware	Integrated keyboard, mouse, and LCD.
Rear SDR interfaces	Tx1, Tx2, Rx1, Rx2, 10 MHz, 1PPS, and optional GPS reference port.
Appliance power note from ground-station kit chapter	230 V AC, maximum power consumption stated as 500 W.
Port mapping note from ground-station kit chapter	Rx1/Tx1 correspond to VHF, Rx2/Tx2 correspond to UHF, and S-band can be used on either port.

Compatibility and Configurations

Category	Description
Supported SDR and source options	USRP BSeries, USRP NSeries, USRP XSeries, SpectralNet, VRT Radio, and file-based IQ sources.
Supported satellite transceivers	Selected compatible transceiver families include GOMSpace AX100, GOMSpace AX2150, Satlab SRS-3/4, AAC Clyde Space, EnduroSat UHF Transceiver II, and GAUSS.
Deployment styles	Software-led deployment with supported external radio hardware, integrated modem appliance deployment, and broader ground-station solution deployment.
Operational access model	Local operation, API-driven integration, and browser-based access paths are supported by the documented interface set.

Data Exchange Summary

- Generic Expedite packet structure: preamble, total length, message type, IRIG-B timetag, data payload, CRC32, and postamble.

- Default preamble: 0xA1B2C3D4.
- Default postamble: bitwise negation of the preamble.
- CRC32 polynomial stated in the manual: 0x04C11DB7.
- Telemetry packets include NORAD ID, slant range, altitude, and elevation ahead of the mission payload.
- Raw IQ is published through ZeroMQ with topic `rawiq`.

Topic	Note
Configuration Notes	Certain capabilities are build-, license-, or hardware-dependent. The manual also distinguishes between <code>MINI_EXPEDITE</code> and non-mini streaming availability for selected services.
Publication Scope	Technical summary based on the documented Expedite baseline.
